

GARMIN

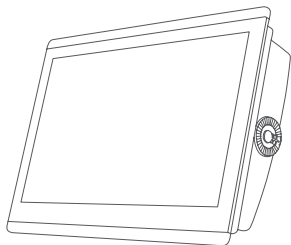

GPSMAP® 8400/8600 SERIES INSTALLATION INSTRUCTIONS

Important Safety Information

⚠ WARNING

See the *Important Safety and Product Information* guide in the product box for product warnings and other important information.

When connecting the power cable, do not remove the in-line fuse holder. To prevent the possibility of injury or product damage caused by fire or overheating, the appropriate fuse must be in place as indicated in the product specifications. In addition, connecting the power cable without the appropriate fuse in place voids the product warranty.

⚠ CAUTION

Always wear safety goggles, ear protection, and a dust mask when drilling, cutting, or sanding.

NOTICE

When drilling or cutting, always check what is on the opposite side of the surface.

To obtain the best performance and to avoid damage to your boat, install the device according to these instructions.

Read all installation instructions before proceeding with the installation. If you experience difficulty during the installation, contact Garmin® Product Support.

Contacting Garmin Support

- Go to support.garmin.com for help and information, such as product manuals, frequently asked questions, videos, and customer support.
- In the USA, call 913-397-8200 or 1-800-800-1020.
- In the UK, call 0808 238 0000.
- In Europe, call +44 (0) 870 850 1241.

Updating the Device Software

You may need to update the device software when you install this device or add an accessory to the network. You can use one of two methods to update the software.

- Use the ActiveCaptain™ app.
- Download the update from www.garmin.com/support/software/marine.html using a memory card (32 GB max.) and a computer running Windows® operating system.

For more information, see the owner's manual at www.garmin.com/manuals/GPSMAP84xx-86xx.

Registering Your Device

Help us better support you by completing our online registration today. You can register your device using one of two methods.

- Use the ActiveCaptain app.

- Go to my.garmin.com/registration and sign into your Garmin account to register the device.

Keep the original sales receipt, or a photocopy, in a safe place. After you add devices to the chartplotter network, register the new devices.

Tools Needed

- Drill and drill bits
 - 3.0 mm ($1/8$ in.) drill bit for bail mounting
 - 14.6 mm ($9/16$ in.) drill bit for flush mounting
 - 3.2 mm ($1/8$ in.) drill bit for flush mounting using wood screws
 - 3.6 mm ($9/64$ in.) drill bit for flush mounting using the nut plate
 - 6.0 mm ($1/4$ in.) drill bit for flush mounting using the nut plate
- #2 Phillips screwdriver
- Jigsaw or rotary tool
- File and sandpaper
- Marine-grade sealant, approved for use on plastics (recommended)

Mounting Considerations

NOTICE

This device should be mounted in a location that is not exposed to extreme temperatures or conditions. The temperature range for this device is listed in the product specifications. Extended exposure to temperatures exceeding the specified temperature range, in storage or operating conditions, may cause device failure. Extreme-temperature-induced damage and related consequences are not covered by the warranty.

You can flush mount the device in the dashboard, or bail mount the device on the dashboard.

When selecting a mounting location, observe these considerations.

- You should mount the device to provide an optimal viewing angle as you operate your boat.
- You must select a location that is strong enough to support the weight of the device and protect it from excessive vibration or shock.
- To avoid interference with a magnetic compass, you must not mount the device closer to a compass than the compass-safe distance value listed in the product specifications.
- You must select a location that allows room for the routing and connection of all cables.
- You should select a location that allows for easy access to the device touchscreen.
- You should select a location that allows for access to the microSD® card in the back of the device. If the location does not allow access, you must insert the memory cards before installing the device.

Bail Mounting the Device

NOTICE

If you are mounting the bracket on fiberglass with screws, it is recommended to use a countersink bit to drill a clearance counterbore through only the top gel-coat layer. This will help to avoid cracking in the gel-coat layer when the screws are tightened.

You can use the bracket to bail mount the device on a flat surface. The bracket and hardware are included in some models.

- Using the bail-mount bracket ① as a template, mark the pilot holes ②.

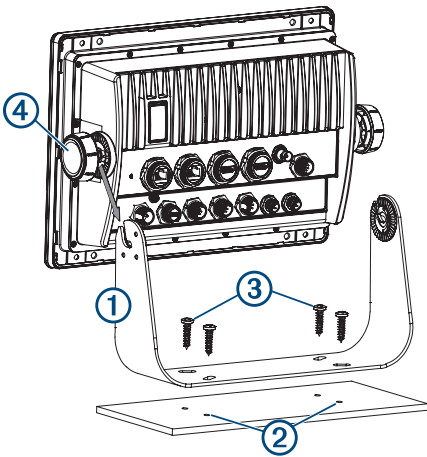

- Using a 3 mm ($1/8$ in.) drill bit, drill the pilot holes.
- Secure the bail-mount bracket to the surface using the included washers and wood screws ③.
- Install the bail-mount knobs ④ on the sides of the device.
- Place the device in the bail-mount bracket, and tighten the bail-mount knobs.
- Install the trim caps by snapping them in place around the edges of the device.

Mounting the Device

NOTICE

Be careful when cutting the hole to flush mount the device. There is only a small amount of clearance between the case and the mounting holes, and cutting the hole too large could compromise the stability of the device after it is mounted.

Use only the included hardware when mounting this device. Using mounting hardware not provided with the device may damage the device.

To avoid potential damage to the powder coating, use only the included screws to mount the device. Using screws other than the ones included will void your warranty.

Do not remove the blue, rubber protective bumper until after the installation is complete. The bumper helps protect the device from damage during installation.

If you will not have access to be back of the device and the microSD memory card slots after installations, you should install the microSD memory card prior to installation.

The included template and hardware can be used to flush mount the device in your dashboard. There are three options for hardware based on the mounting surface material.

- You can drill pilot holes and use the included wood screws.
- You can drill holes and use the included nut plates and machine screws. The nut plates can add stability to a thinner surface.
- You can drill holes, tap them to M4, and use the included machine screws.

- Trim the template and make sure it fits in the location where you want to mount the device.
- Secure the template to the selected location.
- Using an 14.6 mm ($9/16$ in.) drill bit, drill one or more of the holes inside the corners of the solid line on the template to prepare the mounting surface for cutting.
- Using a jigsaw or rotary tool, cut the mounting surface along the **inside** of the solid line on the template.
- Place the device in the cutout to test the fit.

- If necessary, use a file and sandpaper to refine the size of the cutout.
- After the device fits correctly in the cutout, ensure the mounting holes on the device line up with the larger 6 mm ($1/4$ in.) holes on the template.
- If the mounting holes on the device do not line up, mark the new hole locations.
- Based on your mounting surface, drill or punch and tap the larger holes:
 - Drill 3.2 mm ($1/8$ in.) pilot holes for the included wood screws, and skip to step 18.
 - Drill 6 mm ($1/4$ in.) holes for the included nut plate and machine screws.
 - Drill and tap M4 holes for the included machine screws, and skip to step 18.
- If using the nut plates, starting in one corner of the template, place a nut plate ① over the larger hole ② drilled in step 9.

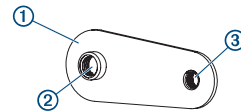

The smaller hole ③ on the nut plate should line up with the smaller 3.6 mm ($9/64$ in.) hole on the template.

- If the smaller hole on the nut plate does not line up with the smaller hole on the template, mark the new hole location.
- Repeat steps 10 and 11 for each nut plate.
- Using a 3.6 mm ($9/64$ in.) drill bit, drill the smaller holes.
- Remove the template from the mounting surface.
- Starting in one corner of the mounting location, place a nut plate ④ on the back of the mounting surface, lining up the large and small holes.

The raised portion of the nut plate should fit into the larger hole.

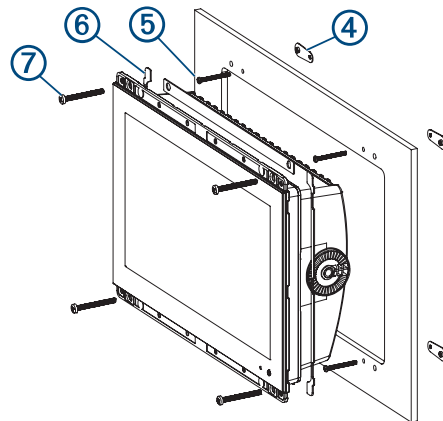

- Secure the nut plate to the mounting surface by fastening an included M3 screw ⑤ through the smaller 3.6 mm ($9/64$ in.) hole.
- Repeat steps 15 and 16 for each of the nut plates along the top and bottom of the device.
- Install the foam gasket ⑥ on the back of the device. The pieces of the foam gasket have adhesive on the back. Make sure you remove the protective liner before installing them on the device.
- If you will not have access to the back of the device after you mount it, connect all necessary cables and install microSD cards in the back of the device before placing it into the cutout.

NOTE: To prevent corrosion of the metal contacts, cover unused connectors with the attached weather caps.

20 Apply marine sealant between the mounting surface and the device to properly seal and prevent leakage behind the dashboard.

21 If you will have access to the back of the device, apply marine sealant around the cutout.

22 Place the device into the cutout.

23 Secure the device to the mounting surface using the included M4 screws **7** or wood screws, depending on the mounting method.

24 Carefully remove and discard the rubber protective bumper.

25 Wipe away all excess marine sealant.

26 Install the trim caps by snapping them in place around the edges of the device.

Connection Considerations

When connecting this device to power and to other Garmin devices, you should observe these considerations.

- The power and ground connections to the battery must be checked to make sure they are secured and cannot become loose.
- The cables may be packaged without the locking rings installed. The cables should be routed before the locking rings are installed.
- After installing a locking ring on a cable, you should make sure the ring is securely connected and the o-ring is in place so the power or data connection remains secure.

Connecting to Power

⚠ WARNING

When connecting the power cable, do not remove the in-line fuse holder. To prevent the possibility of injury or product damage caused by fire or overheating, the appropriate fuse must be in place as indicated in the product specifications. In addition, connecting the power cable without the appropriate fuse in place voids the product warranty.

- 1** Route the power cable to the power source and to the device.
- 2** Connect the red wire to the positive (+) battery terminal, and connect the black wire to the negative (-) battery terminal.
- 3** Connect the power cable to the device, and turn the locking ring clockwise to tighten it.

Additional Grounding Consideration

This device should not need additional chassis grounding in most installation situations. If you experience interference, you can use the grounding screw on the housing to connect the device to the water ground of the boat to help avoid the interference.

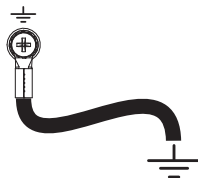

Power Cable Extensions

If necessary, the power cable can be extended using the appropriate wire gauge for the length of the extension.

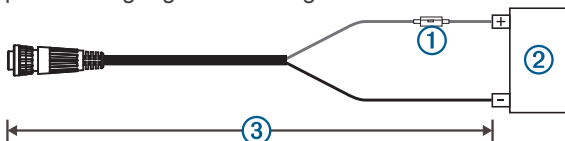

| Item | Description |
|------|----------------------------|
| ① | Fuse |
| ② | Battery |
| ③ | 6 ft. (1.8 m) no extension |

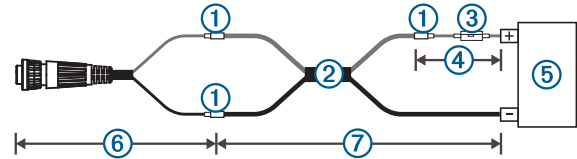

| Item | Description |
|------|---|
| ① | Splice |
| ② | <ul style="list-style-type: none"> • 10 AWG (5.26 mm²) extension wire, up to 15 ft. (4.6 m) • 8 AWG (8.36 mm²) extension wire, up to 23 ft. (7 m) • 6 AWG (13.29 mm²) extension wire, up to 36 ft. (11 m) |
| ③ | Fuse |
| ④ | 8 in. (20.3 cm) |
| ⑤ | Battery |
| ⑥ | 8 in. (20.3 cm) |
| ⑦ | 36 ft. (11 m) maximum extension |

Garmin Marine Network Considerations

NOTICE

A Garmin Power over Ethernet (PoE) Isolation Coupler (P/N 010-10580-10) must be used when connecting any third-party device, such as a FLIR® camera, to a Garmin Marine Network. Connecting a PoE device directly to a Garmin Marine Network chartplotter damages the Garmin chartplotter and may damage the PoE device. Connecting any third-party device directly to a Garmin Marine Network chartplotter will cause abnormal behavior on the Garmin devices, including the devices not properly turning off or the software becoming inoperable.

This device can connect to additional Garmin Marine Network devices to share data such as radar, sonar, and detailed mapping. When connecting Garmin Marine Network devices to this device, observe these considerations.

- All devices connected to the Garmin Marine Network must be connected to the same ground.
- A Garmin Marine Network cable must be used for all Garmin Marine Network connections.
 - Third-party CAT5 cable and RJ45 connectors must not be used for Garmin Marine Network connections.
 - Additional Garmin Marine Network cables and connectors are available from your Garmin dealer.
- The NETWORK ports on the device each act as a network switch. Any compatible device can be connected to any NETWORK port to share data with all devices on the boat connected by a Garmin Marine Network cable.

Station Connection Considerations

This device can be set up in conjunction with other compatible Garmin devices to work together as a station. When planning stations on your boat, observe these considerations.

- Devices earlier than the GPSMAP 8000 series and GPSMAP 8500 series cannot be used in a station.
- Although it is not necessary, it is recommended that you install all of the devices you plan to use in one station near each other.
- No special connections are necessary to create a station, as long as all of the devices are connected to the Garmin Marine Network (*Garmin Marine Network Considerations*, page 3).

- Stations are created and modified using the device software. See the owner's manual provided with the device for more information.

NMEA 2000® Considerations

NOTICE

If you are connecting to an **existing** NMEA 2000 network, identify the NMEA 2000 power cable. Only one NMEA 2000 power cable is required for the NMEA 2000 network to operate properly.

A NMEA 2000 Power Isolator (010-11580-00) should be used in installations where the existing NMEA 2000 network manufacturer is unknown.

If you are installing a NMEA 2000 power cable, you must connect it to the boat ignition switch or through another in-line switch. NMEA 2000 devices will drain your battery if the NMEA 2000 power cable is connected to the battery directly.

This device can connect to a NMEA 2000 network on your boat to share data from NMEA 2000 compatible devices such as a GPS antenna or a VHF radio. The included NMEA 2000 cables and connectors allow you to connect the device to your existing NMEA 2000 network. If you do not have an existing NMEA 2000 network you can create a basic one using cables from Garmin.

If you are unfamiliar with NMEA 2000, you should read the "NMEA 2000 Network Fundamentals" chapter of the *Technical Reference for NMEA 2000 Products*. You can find this document using the "Manuals" link on the product page for your device at www.garmin.com.

The port labeled NMEA 2000 is used to connect the device to a standard NMEA 2000 network.

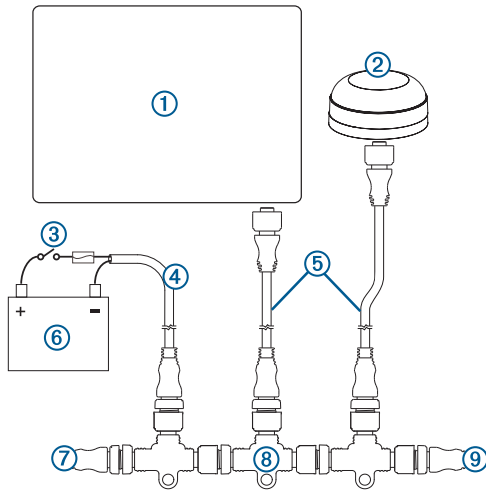

| Item | Description |
|------|--|
| ① | NMEA 2000 compatible Garmin device |
| ② | GPS antenna |
| ③ | Ignition or in-line switch |
| ④ | NMEA 2000 power cable |
| ⑤ | NMEA 2000 drop cable |
| ⑥ | 12 Vdc power source |
| ⑦ | NMEA 2000 terminator or backbone cable |
| ⑧ | NMEA 2000 T-connector |
| ⑨ | NMEA 2000 terminator or backbone cable |

J1939 Engine Network Connection Considerations

NOTICE

You must use a Garmin GPSMAP J1939 accessory cable when connecting the chartplotter to the J1939 engine network to prevent corrosion due to moisture. Using a different cable voids your warranty.

If you have an existing engine network on your boat, it should already be connected to power. Do not add any additional power supply.

This chartplotter can connect to an engine network on your boat to read data from compatible devices such as certain engines. The engine network follows a standard and uses proprietary messages.

You should connect only one chartplotter to one engine network. Connecting more than one chartplotter to one engine network may result in unexpected behavior.

The port labeled J1939 is used to connect the device to the existing engine network. You must route the cable within 6 m (20 ft.) of the engine network backbone.

The Garmin GPSMAP J1939 accessory cable requires connection to a power source and proper termination. For more information on connecting to your engine network, see the manufacturer's engine documentation.

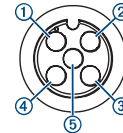

| Pin | Wire Color | Description |
|-----|------------|-----------------|
| ① | Bare | Shield |
| ② | Red | Power, positive |
| ③ | Black | Power, negative |
| ④ | White | CAN High |
| ⑤ | Blue | CAN Low |

HDMI® Video Considerations

NOTICE

To prevent corrosion due to moisture, you must use Garmin GPSMAP accessory cables when connecting the chartplotter to the video source or display. Do not connect a media player stick directly into the back of the chartplotter. Using different cables or connecting a media player stick into the back of the chartplotter voids your warranty.

This chartplotter allows video input from HDMI video sources, such as a Chromecast™ device or a Blu-Ray™ player. You can view protected HDMI content (HDCP content) on the chartplotter screen. HDMI video is shared across the Garmin Marine Network, but it is not shared across the NMEA 2000 network. HDCP content is not shared across the Garmin Marine Network.

Through the HDMI OUT port, you can duplicate the chartplotter screen on another device, such as a television or monitor. You cannot view HDCP content on the duplicated screen.

The Garmin GPSMAP HDMI accessory cable is 4.5 m (15 ft) long. If you need a longer cable, you should use an active HDMI cable only. You need an HDMI coupler to connect the two HDMI cables.

You need a Garmin GPSMAP USB OTG adapter cable to power a media player stick. The USB port can supply up to 2.5 W to power a media player stick.

You must make all cable connections in a dry environment.

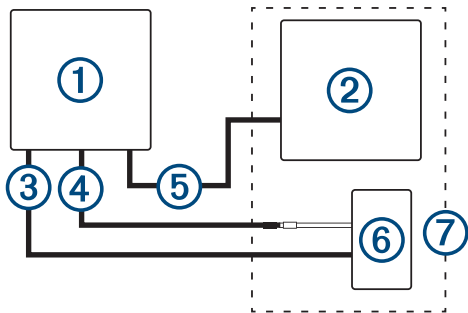

| Item | Description |
|------|--|
| ① | GPSMAP 8400/8600 chartplotter |
| ② | Display with an HDMI In port, such as a computer or television |
| ③ | GPSMAP HDMI cable (HDMI IN) |
| ④ | GPSMAP USB OTG adapter cable to power the HDMI source, if possible (2.5 W maximum) |
| ⑤ | GPSMAP HDMI cable (HDMI OUT) |
| ⑥ | HDMI source, such as a Blu-Ray player or Chromecast device |
| ⑦ | Dry environment, protected from moisture |

Composite Video Considerations

This chartplotter allows video input from composite video sources using the port labeled CVBS IN. When connecting composite video, you should observe these considerations.

- The CVBS IN port uses a BNC connector. You can use a BNC to RCA adapter to connect a composite-video source with RCA connectors to the CVBS IN port.
- Video is shared across the Garmin Marine Network, but it is not shared across the NMEA 2000 network.

Touchscreen Controls for a Connected Computer

NOTICE

To prevent corrosion due to moisture, you must use Garmin GPSMAP accessory cables when connecting the chartplotter to the computer. Using different cables voids your warranty.

You can connect the chartplotter to a computer to see the computer screen and to control the computer using the chartplotter touchscreen. To see the computer screen, you must connect the computer to the HDMI IN port. To control the computer using the chartplotter touchscreen, you must connect the computer to the USB port.

The Garmin GPSMAP HDMI accessory cable is 4.5 m (15 ft) long. If you need a longer cable, you should use an active HDMI cable only. You need an HDMI coupler to connect the two HDMI cables. You must make all cable connections in a dry environment.

The Garmin GPSMAP USB accessory cable is 4.5 m (15 ft) long. If you need a longer cable, you should use a USB hub or USB repeater extension cable only. You should make all cable connections in a dry environment.

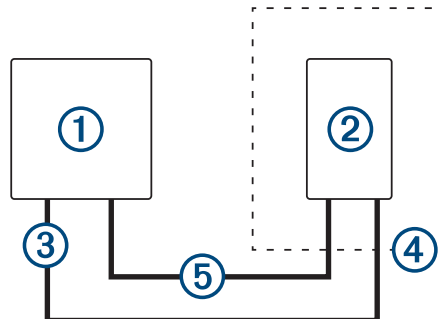

| Item | Description |
|------|--|
| ① | Garmin chartplotter |
| ② | Computer |
| ③ | GPSMAP USB cable |
| ④ | Dry environment, protected from moisture |
| ⑤ | GPSMAP HDMI cable (HDMI IN) |

NMEA® 0183 with Audio Cable Pinout

The optional NMEA 0183 with audio cable (010-12852-00) includes bare wires and an RCA connector for an audio out connection to a stereo, including FUSION® stereos. This cable can be purchased from garmin.com or your local Garmin dealer.

After installing, you can connect the RCA connector to the AUX input of the stereo. The HDMI input is output to the stereo.

The NMEA 0183 with audio cable provides one differential NMEA 0183 input and output port.

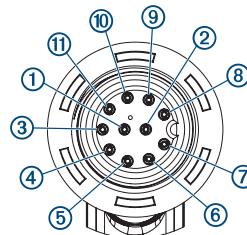

| Pin | Wire Function | Wire Color |
|-----|------------------------|--------------|
| 1 | NMEA 0183 Rx/A (In +) | Orange/white |
| 2 | NMEA 0183 Rx/B (In -) | White |
| 3 | NMEA 0183 Tx/B (Out -) | Pink |
| 4 | NMEA 0183 Tx/A (Out +) | Gray |
| 5 | Ground | Black |
| 6 | Alarm | Yellow |
| 7 | Accessory on | Orange |
| 8 | Ground (shield) | Brown |
| 9 | Audio Left Channel | White |
| 10 | Audio Common | Blue/red |
| 11 | Audio Right Channel | Red |

For more information on NMEA 0183 wiring with this cable, see the cable instructions at www.garmin.com/manuals/nmea0183_audio_cable.

NMEA 0183 Connection Considerations

- The chartplotter provides one Tx (transmit) port and one Rx (receive) port.
- Each port has 2 wires, labeled A and B according to the NMEA 0183 convention. The corresponding A and B wires of each internal port should be connected to the A (+) and B (-) wires of the NMEA 0183 device.
- You can connect one NMEA 0183 device to the Rx port to input data to this chartplotter, and you can connect up to

three NMEA 0183 devices in parallel to the Tx port to receive data output by this chartplotter.

- See the NMEA 0183 device installation instructions to identify the transmit (Tx) and receive (Rx) wires.
- You must use 28 AWG, shielded, twisted-pair wiring for extended runs of wire. Solder all connections and seal them with heat-shrink tubing.
- Do not connect the NMEA 0183 data wires from this device to power ground.
- The power cable from the chartplotter and the NMEA 0183 devices must be connected to a common power ground.
- The internal NMEA 0183 ports and communication protocols are configured on the chartplotter. See the NMEA 0183 section of the chartplotter owner's manual for more information.
- See the chartplotter owner's manual for a list of the approved NMEA 0183 sentences that the chartplotter supports.

Specifications

| Device | Specification | Measurement |
|------------------|---------------------------------------|--|
| All models | Temperature range | From -15° to 55°C (from 5° to 131°F) |
| | Material | Polycarbonate plastic and die-cast aluminum |
| | Water rating ¹ | IEC 60529 IPX7 |
| | Input voltage | From 10 to 32 Vdc |
| | Fuse | 10 A, 125 V fast-acting |
| | NMEA 2000 LEN | 2 |
| | NMEA 2000 draw | 75 mA max. |
| | Max. waypoints | 5,000 |
| | Max. routes | 100 (250 waypoints each) |
| | Max. active track points | 50,000 points, 50 saved tracks |
| | Memory card | 2 microSD card slots in the back of the device; 32 GB max. card size |
| | Wireless frequency and protocols | Wi-Fi® and ANT® technologies 2.4 GHz @ 12.3 dBm nominal |
| HTML integration | Compatible with OneHelm™ integration | |
| 10-inch models | Dimensions (W × H × D) | 259.9 × 205.1 × 75.1 mm (10 ¹ / ₄ × 8 ¹ / ₁₆ × 2 ¹⁵ / ₁₆ in.) |
| | Display size (W × H) | 136.9 × 218.4 mm (5 ³ / ₈ × 8 ⁵ / ₈ in.) |
| | Weight | 2.4 kg (5.2 lb.) |
| | Clearance behind flush-mounted device | 11.1 cm (4 ³ / ₈ in.) |
| | Compass-safe distance | 45 cm (17.7 in.) |
| | Max. power usage at 10 Vdc | 40.1 W |
| | Typical current draw at 12 Vdc | 1.5 A |
| | Max. current draw at 12 Vdc | 6.0 A |
| 12-inch models | Dimensions (W × H × D) | 302.8 × 216.4 × 75.1 mm (11 ¹⁵ / ₁₆ × 8 ¹ / ₂ × 2 ¹⁵ / ₁₆ in.) |
| | Display size (W × H) | 257.3 × 145.2 mm (10 ¹ / ₈ × 5 ¹¹ / ₁₆ in.) |
| | Weight | 2.7 kg (6.0 lb.) |
| | Clearance behind flush-mounted device | 11.1 cm (4 ³ / ₈ in.) |
| | Compass-safe distance | 35 cm (13.8 in.) |
| | Max. power usage at 10 Vdc | 45 W |

| Device | Specification | Measurement |
|----------------|---------------------------------------|---|
| | Typical current draw at 12 Vdc | 1.3 A |
| | Max. current draw at 12 Vdc | 6.0 A |
| 16-inch models | Dimensions (W × H × D) | 384.7 × 262.6 × 75.1 mm (15 ¹ / ₈ × 10 ⁵ / ₁₆ × 2 ¹⁵ / ₁₆ in.) |
| | Display size (W × H) | 345.2 × 194.6 mm (13 ⁹ / ₁₆ × 7 ¹¹ / ₁₆ in.) |
| | Weight | 4.4 kg (9.6 lb.) |
| | Clearance behind flush-mounted device | 11.1 cm (4 ³ / ₈ in.) |
| | Compass-safe distance | 105 cm (41.3 in.) |
| | Max. power usage at 10 Vdc | 52.1 W |
| | Typical current draw at 12 Vdc | 1.3 A |
| | Max. current draw at 12 Vdc | 6.0 A |
| Sonar models | Frequencies ² | Traditional: 50/200, 77/200, 83/200 kHz Single Channel CHIRP: from 40 to 240 kHz Garmin ClearVü CHIRP: 260/455/800 kHz Ultra High-Definition SideVü : 1,200 kHz, CHIRP range: 1,060 to 1,170 kHz (dependent on transducer) |
| | Transmit power (RMS) ³ | CHIRP: 1000 W Garmin ClearVü and SideVü CHIRP: 500 W |
| | Depth ⁴ | 5,000 ft. at 1 kW |

¹The device withstands incidental exposure to water of up to 1 m for up to 30 min. For more information, go to www.garmin.com/waterrating.

²Dependent upon the transducer.

³Dependent upon the transducer rating and depth.

⁴Dependent upon the transducer, water salinity, bottom type, and other water conditions.

NMEA 2000 PGN Information Transmit and Receive

| PGN | Description |
|--------|---|
| 059392 | ISO acknowledgment |
| 059904 | ISO request |
| 060160 | ISO transport protocol: Data transfer |
| 060416 | ISO transport protocol: Connection management |
| 060928 | ISO address claimed |
| 065240 | Commanded address |
| 126208 | Request group function |
| 126996 | Product information |
| 126998 | Configuration information |
| 127237 | Heading/track control |
| 127245 | Rudder |
| 127250 | Vessel heading |
| 127258 | Magnetic variance |
| 127488 | Engine parameters: Rapid update |
| 127489 | Engine parameters: Dynamic |
| 127493 | Transmission parameters: Dynamic |
| 127505 | Fluid level |
| 127508 | Battery status |
| 128259 | Speed: Water referenced |

| PGN | Description |
|--------|-------------------------------------|
| 128267 | Water depth |
| 129025 | Position: Rapid update |
| 129026 | COG and SOG: Rapid update |
| 129029 | GNSS position data |
| 129283 | Cross track error |
| 129284 | Navigation data |
| 129539 | GNSS DOPs |
| 129540 | GNSS satellites in view |
| 130060 | Label |
| 130306 | Wind data |
| 130310 | Environmental parameters (obsolete) |
| 130311 | Environmental parameters (obsolete) |
| 130312 | Temperature (obsolete) |

Transmit

| PGN | Description |
|--------|--|
| 126464 | Transmit and receive PGN list group function |
| 126984 | Alert Response |
| 127497 | Trip parameters: Engine |

Receive

| PGN | Description |
|--------|--|
| 065030 | Generator average basic AC quantities (GAAC) |
| 126983 | Alert |
| 126985 | Alert text |
| 126987 | Alert threshold |
| 126988 | Alert value |
| 126992 | System time |
| 127251 | Rate of turn |
| 127257 | Attitude |
| 127498 | Engine parameters: Static |
| 127503 | AC input status (obsolete) |
| 127504 | AC output status (obsolete) |
| 127506 | DC detailed status |
| 127507 | Charger status |
| 127509 | Inverter status |
| 128000 | Nautical leeway angle |
| 128275 | Distance log |
| 129038 | AIS class A position report |
| 129039 | AIS class B position report |
| 129040 | AIS class B extended position report |
| 129044 | Datum |
| 129285 | Navigation: Route, waypoint information |
| 129794 | AIS class A static and voyage related data |
| 129798 | AIS SAR aircraft position report |
| 129799 | Radio frequency/mode/power |
| 129802 | AIS safety-related broadcast message |
| 129808 | DSC call Information |
| 129809 | AIS class B "CS" static data report, part A |
| 129810 | AIS class B "CS" static data report, part B |
| 130313 | Humidity |
| 130314 | Actual pressure |
| 130316 | Temperature: Extended range |
| 130576 | Trim tab status |
| 130577 | Direction data |

| Sentence | Description |
|----------|----------------------------------|
| 61443 | Electronic engine controller 2 |
| 61444 | Electronic engine controller 1 |
| 65031 | Exhaust temperature |
| 65172 | Engine auxiliary coolant |
| 65252 | Shutdown |
| 65253 | Engine hours and revolutions |
| 65262 | Engine temperature 1 |
| 65263 | Engine fluid level or pressure 1 |
| 65270 | Inlet or exhaust conditions 1 |
| 65271 | Vehicle electrical power |
| 65279 | Water in fuel indicator |
| 65272 | Transmission fluids 1 |
| 65248 | Vehicle distance |
| 65266 | Fuel economy (liquid) |
| 65276 | Dash display |
| 65226 | Active diagnostic trouble codes |

© 2019 Garmin Ltd. or its subsidiaries
 Garmin®, the Garmin logo, and GPSMAP® are trademarks of Garmin Ltd. or its subsidiaries, registered in the USA and other countries. These trademarks may not be used without the express permission of Garmin.

HDMI® is a registered trademark of HDMI Licensing, LLC. The microSD® logo is a trademark of SD-3C, LLC. NMEA®, NMEA 2000®, and the NMEA 2000 logo are registered trademarks of the National Marine Electronics Association.

J1939 PGN Information

The chartplotter can receive J1939 PGN sentences. The chartplotter cannot transmit over the J1939 network.

